

NWBK Truck and tank weighing load cell, 10tf - 30tf

Load Cell



FEATURES

- OIML C3 approved(OIML R60)
- Built in lightning protection device
- Ex ia IIC T6 approved
- Protection class IP68

OPTIONS

- C3 approved



SPECIFICATIONS

Max. capacity	tf	10, 25, 30	
Rated output	mV/V	2.0 ± 0.005	
Zero balance	mV/V	0 ± 0.02	
Accuracy class		D3	C3
Combined error	%	0.03	0.02
Repeatability	%	0.02	0.01
Creep for 30min.	%	0.03	0.017
Temperature effect on			
Zero Value	%/10°C	0.03	0.014
Output value	%/10°C	0.03	0.011
Excitation			
Recommended	V	10	
Maximum	V	15	
Resistance			
Input	Ω	350 ± 3.5	
Output	Ω	350 ± 3.5	
Insulation	MΩ	> 2,000	
Compensated temperature range	°C	-10 to +40	
Operating temperature range	°C	-40 to +70	

DIMENSIONS

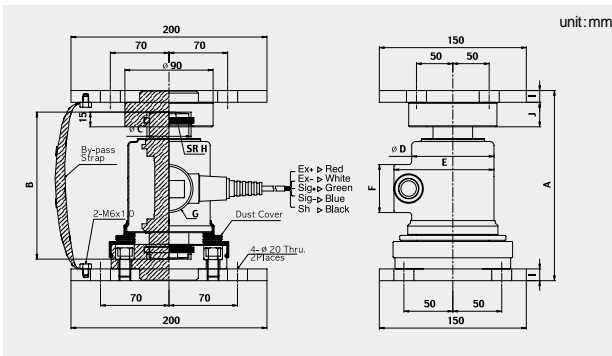

Material

Stainless Steel

Cable

Braided shield 4-wire round cable with P.V.C-jacket
Length: 10m

Model	Capacity	A	B	C	D	E	F	G	H	I	J
NWBK-10	10tf	194	150	45.4	84	107	51	51	250	12	25
NWBK-25	25tf										
NWBK-30	30tf										

